

VCIP 2003



Introduction to MPEG-21



Giordano Beretta
HP Laboratories Palo Alto
8 July 2003

Outline



- What is MPEG-21 ?
- How is MPEG21 structured ?
- Why is MPEG-21 relevant to you ?
- What can you contribute to MPEG-21 ?
- The bottom line

“It was on the 29th of January 1988 that an SC 2 / WG 8 resolution established the Moving Picture Coding Experts Groups”

Leonardo Chiariglione
Telecom Italia Lab

What is MPEG-21 ?



- An open framework for multimedia delivery and consumption
- Focal points:
 - Content creators
 - Content consumers



- MPEG is a working group of ISO
 - ISO/IEC JTC 1/SC 29/WG 11
 - Coding of moving pictures and audio
- Development of international standards for compression, decompression, processing and coded representation of moving pictures, audio, and their combination, in order to satisfy a wide variety of applications

Much of the material on these slides is from <http://mpeg.telecomitalialab.com/>

Application examples

- Video CD, MP3, DVD
- Satellite TV, digital cable, HDTV
- Video on demand
- PC video streaming
 - Apple QuickTime
 - Microsoft Windows Media Player
 - RealNetworks Helix and RealPlayer
- Do-it-yourself



- MPEG-1 and MPEG-2 provide interoperable ways of representing audiovisual content, commonly used on digital media and on the air
- MPEG-4 defines how to *represent* content
- MPEG-7 specifies how to *describe* content
- MPEG-21 provides a truly interoperable multimedia framework

MPEG-1 – ISO/IEC 11172

- Coding of moving pictures and associated audio for digital storage media
- Video and audio at 1.5M bit/s for CD-ROM
- Five parts:
 - Part 1 (systems): multiplexing & synchronization
 - Part 2 (video): ~VHS quality at 1.15M bit/s
 - Part 3 (audio): stereo at 384K, 256K, 192K bit/s
 - Part 4 (conformance testing): references for decoder
 - Part 5 (reference software): C implementation
- Applications: Video CD, MP3

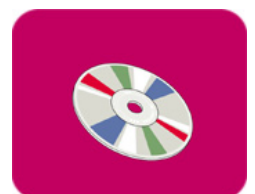

- Generic coding of moving pictures and associated audio
- Digital Storage Media Command and Control (DSM-CC) for session set up and remote control of a server, used in set top boxes for satellite and cable TV
- Advanced Audio Coding (AAC) for multi-channel audio
- 4:2:2 profile for TV production studios
- Provisions for Intellectual Property Management and Protection (IPMP)
- Applications: digital TV set top boxes, DVD
- Transport Stream version
- Patent issues



- Coding of audiovisual objects
- MPEG-4 defines how to *represent* content
 - ancestry: VRML
 - interoperability of content structure
 - AFX — Animation Framework eXtension
 - XMT — textual XML format for SMIL, Web3D, etc.
 - adapt transparently to device capabilities
 - FSG — Fine Granularity Scalability
- Extensions of AAC and IPMP, Studio Profile
- MP4 and AVC file formats, multi-user environment
- Patent issues



- Multimedia content description interface
- MPEG-7 specifies how to *describe* content
 - describe content way beyond metadata
 - facilitate content management, in particular searching

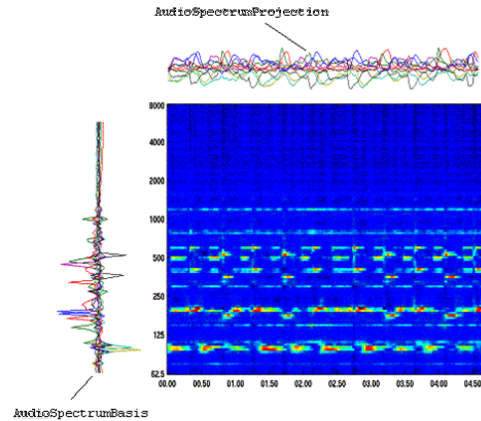
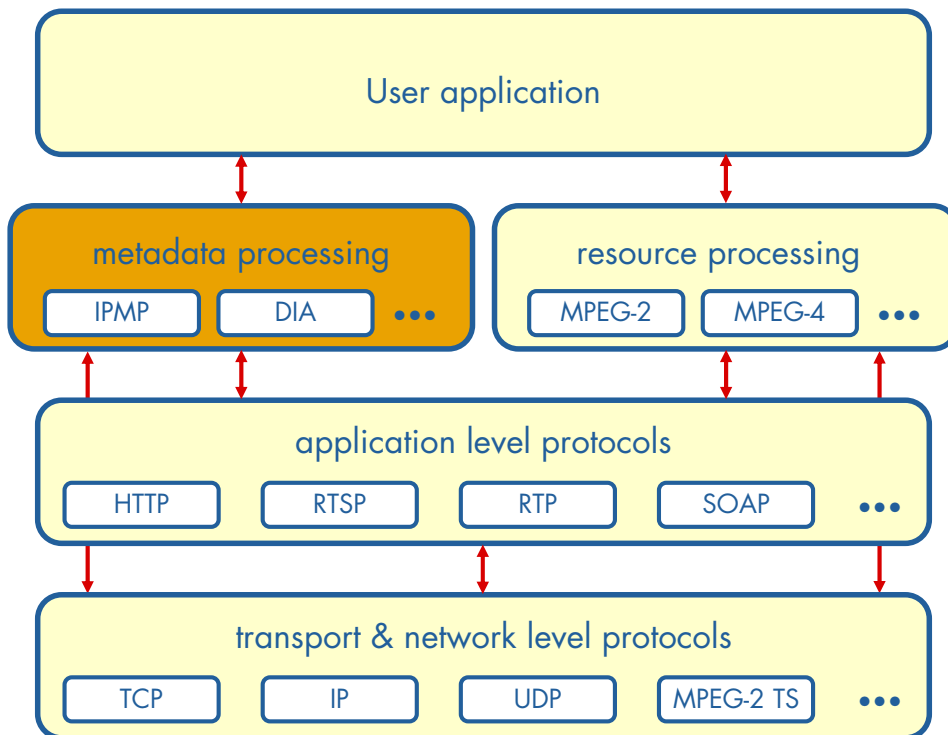

Image credit: <http://mpeg.telecomitalia.com/standards/mpeg-7/mpeg-7.htm>

Define the technology needed to support **Users** to exchange, access, consume, trade and otherwise manipulate **Digital Items** in an efficient, transparent and interoperable way



MPEG-21 Digital Item

- Structured digital objects, including a standard representation and identification, and metadata
- Fundamental unit of distribution and transaction within the MPEG-21 framework
- No further technical meaning

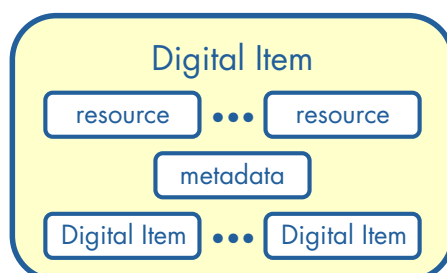

- A **User** is any entity that interacts in the MPEG-21 environment or makes use of a Digital Item
 - Users include individuals, consumers, communities, organisations, corporations, consortia, governments and other standards bodies and initiatives around the world.
- Users are identified specifically by their relationship to another User for a certain interaction
- MPEG-21 makes no distinction between a “content provider” and a “consumer” — both are Users
 - A single entity may use content in many ways
 - however, a User may assume specific or even unique rights and responsibilities according to their interaction with other Users within MPEG-21

MPEG-21 CE testbed

<http://www.midgardmedia.net/UMA/mpeg21main.htm>

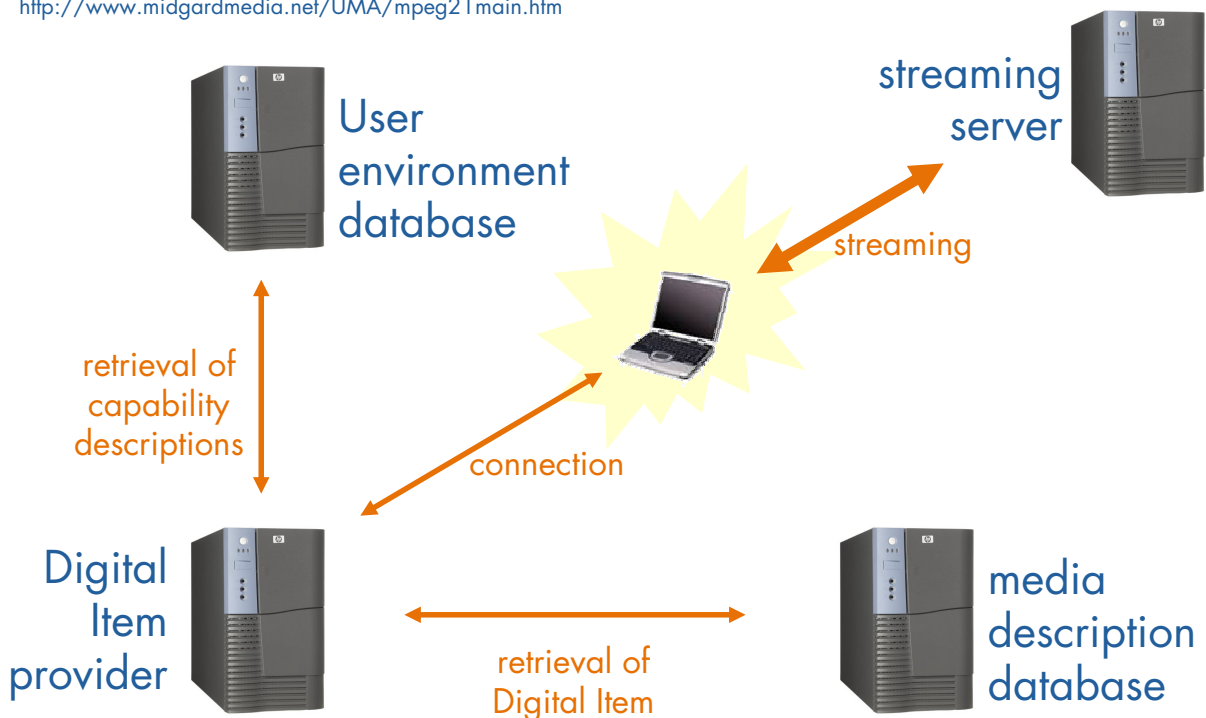

1. Vision, technologies and strategies
2. Digital Item Declaration
3. Digital Item Identification
4. Intellectual Property Management and Protection (IPMP)
5. Rights Expression Language
6. Rights Data Dictionary
7. Digital Item Adaptation
8. Reference Software
9. File Format

MPEG-21 Part 1 — Vision

- Define a multimedia framework to enable transparent and augmented use of multimedia resources across a wide range of networks and devices
1. Provide a vision
 2. Facilitate integration and harmonization of technologies
 3. Provide a strategy for achieving a framework through collaboration



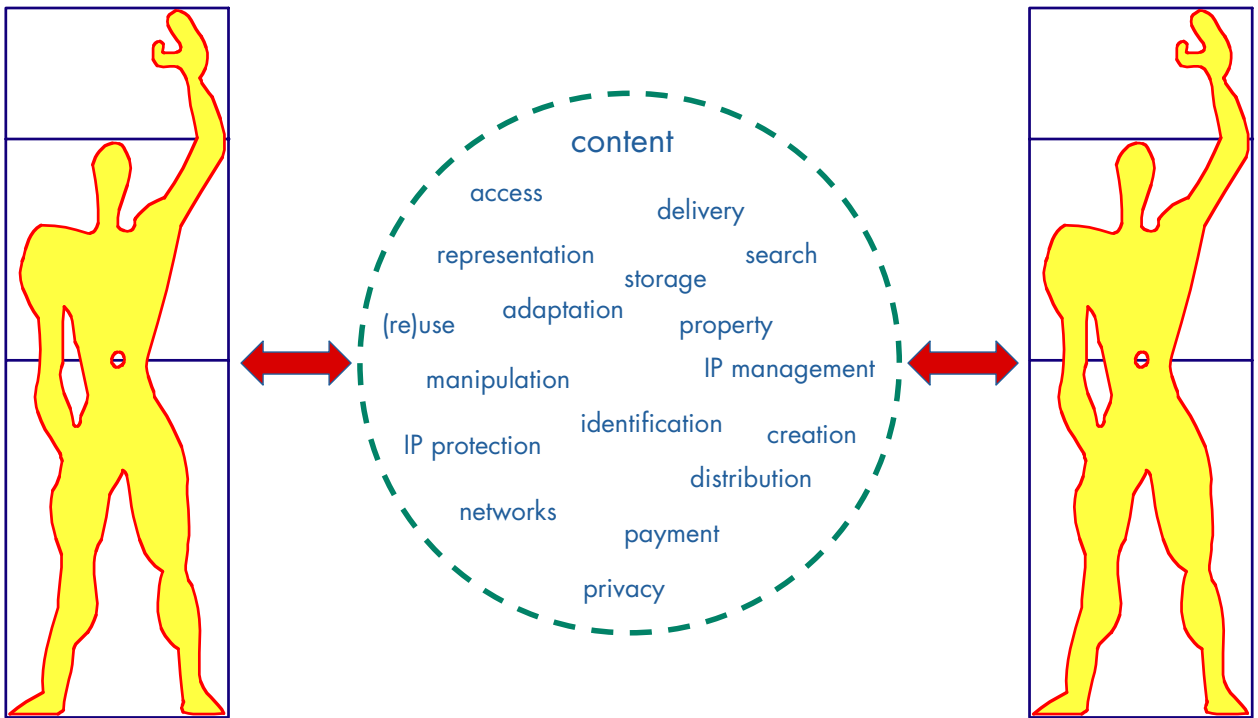

Digital assets

- World Wide Web's phases
 - 1990 (info.cern.ch) — scientific exchange
 - 1995 (tidal wave) — free content
 - 2000 (dot bomb) — ubiquitous fast network
- Users are starting to recognize the value of their digital asset resources
- Markets must be efficient

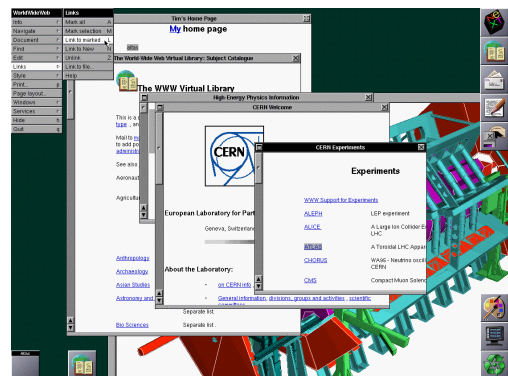



s/w platform owners

h/w platform owners

creators

distributors

service providers

gadget platform owners

fiduciaries

MPEG-21 Part 2 — Digital Item Declaration

- Index a Digital Item
- Purpose: describe a set of abstract terms and concepts to form a useful model for defining Digital Items
- Three normative sections:
 - Model
 - set of abstract terms and concepts
 - Representation
 - normative description of syntax & semantics of DID elements
 - Schema
 - normative XML schema comprising the entire grammar of DID

Digital Item Declaration in detail

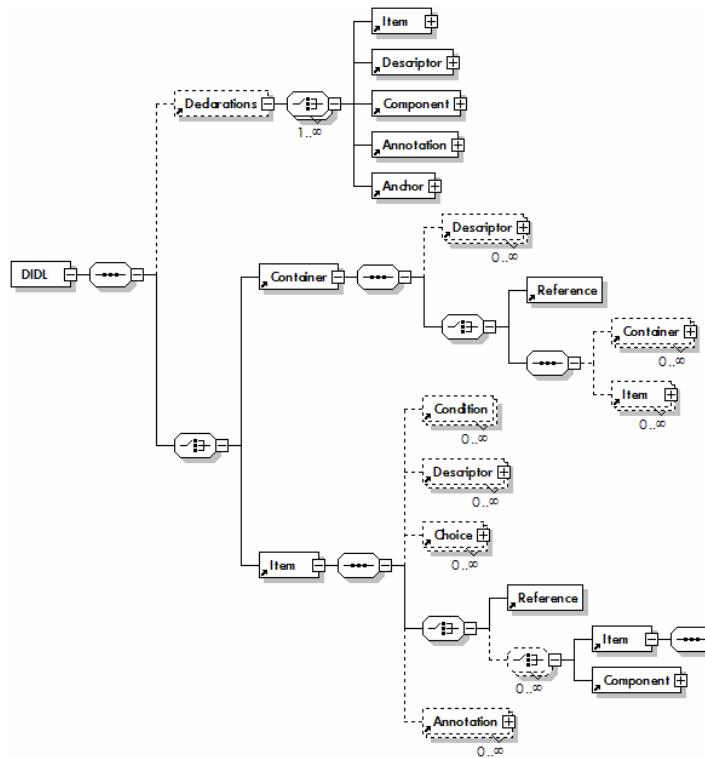

Digital Item Declaration example

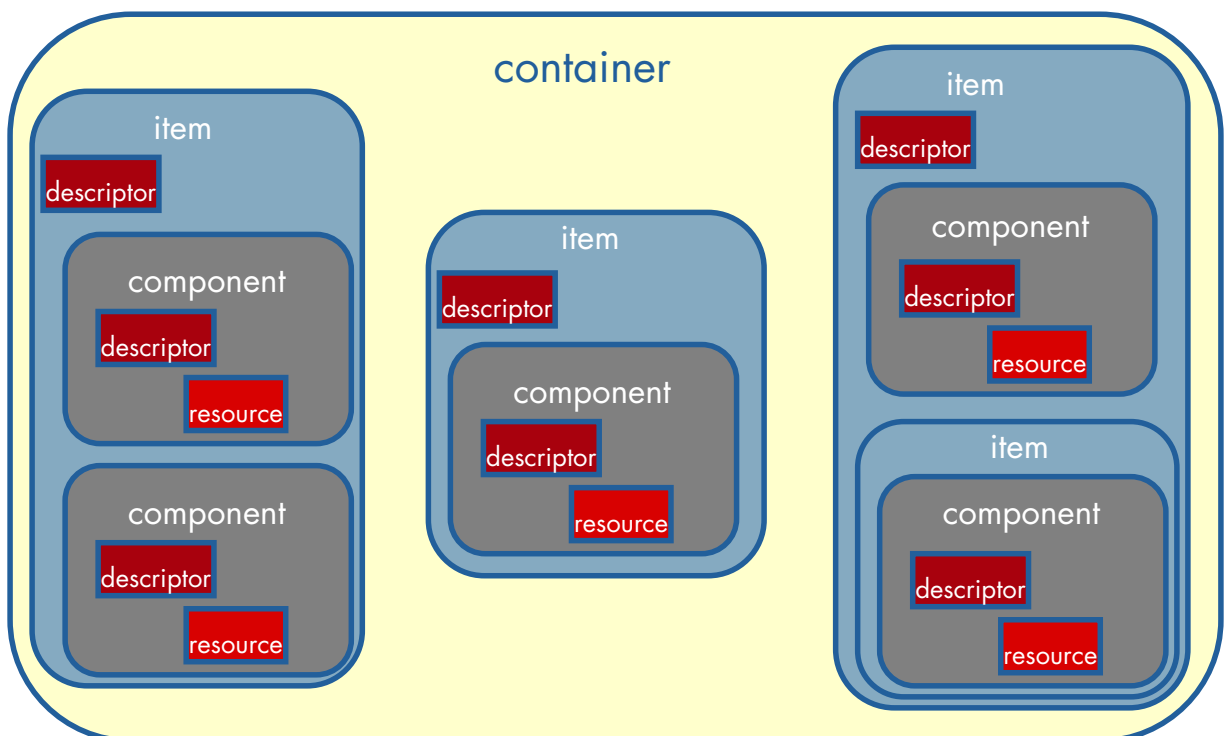

The scope of the Digital Item Identification (DII) specification includes:

- How to uniquely identify Digital Items and parts thereof (including resources)
- How to uniquely identify IP related to the Digital Items (and parts thereof), for example abstractions
- How to uniquely identify Description Schemes
- How to use identifiers to link Digital Items with related information such as descriptive metadata
- How to identify different types of Digital Items

DII example: MPEG-21 music album

N5231

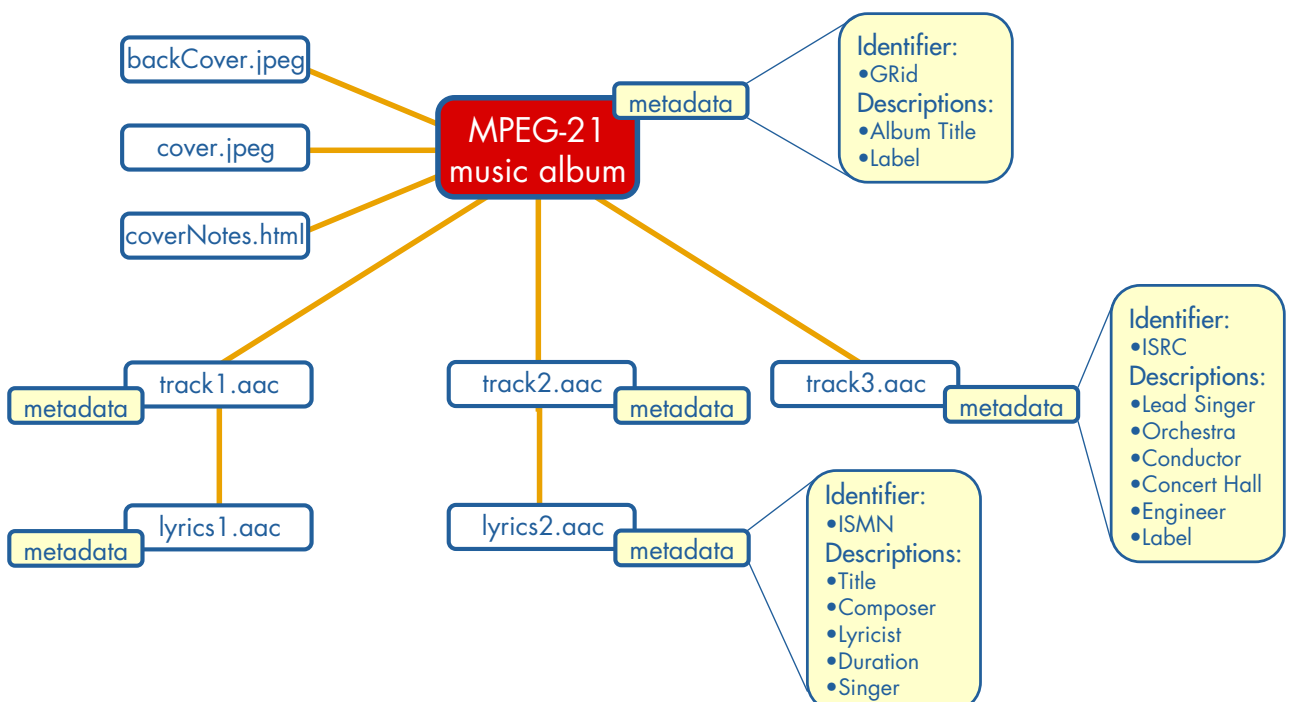

- Improvements over MPEG-4 IPMP:
 - Internetworking
 - IPMP tool retrieval & authentication
 - Integration of Rights Expressions (RDD & REL)
- Intellectual Property Management and Protection involves the enforcement of REL permissions
 - IPMP shall consult REL before any actions are taken in the User's system
- REL: What is protected? What right applies?
IPMP: How is it protected?

- Rights Expression Language
- A machine-readable language
- Can declare rights and permissions
- Uses terms defined in the Rights Data Dictionary

- The Rights Expression Language consists of licenses and grants that give specific permissions to Users to perform certain actions on certain resources, given that certain conditions are met
 - Grants can also allow Users to delegate authority to others
- User's system shall parse and validate the RE
- User's system shall check permissions before any further action is done
- DID parser is responsible for discovering and identifying where to gather licenses
- REL licenses are wrapped in Digital Items

REL data model

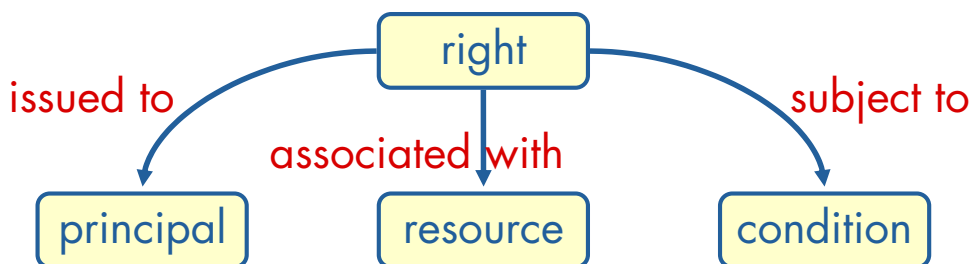

- REL grant consist of
 - principal to whom grant is issued
 - rights the grant specifies
 - resource to which right in grant applies
 - condition to be met before grant can be exercised

- Set of clear, consistent, structured, integrated and uniquely identified Terms to support REL
- Specification of dictionary structure and methodology to create dictionary
- Dictionary is prescriptive, inclusive, and has audit provisions
- Legal definitions are mapped from other Authorities
- Supports mapping & transformation of metadata from terminology of one namespace (or Authority) into that of another namespace in automated or partially-automated way
- Dictionary is based on a logical model, the Context Model, which is the basis of the dictionary ontology

- Goal: achieve transparent interoperable access to distributed multimedia content
- Enable ad hoc formation of User communities in which contents is shared with agreed or contracted
 - Quality
 - Reliability
 - Flexibility
 - Diversity
- Guaranteed user experience

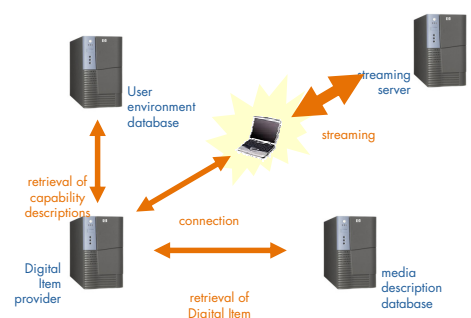
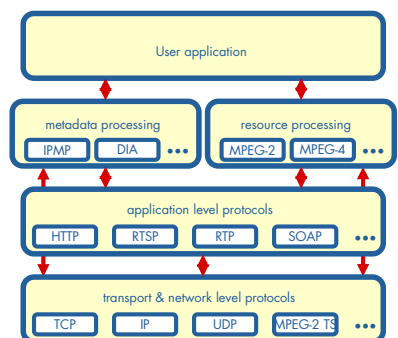

Concept of Digital Item Adaptation

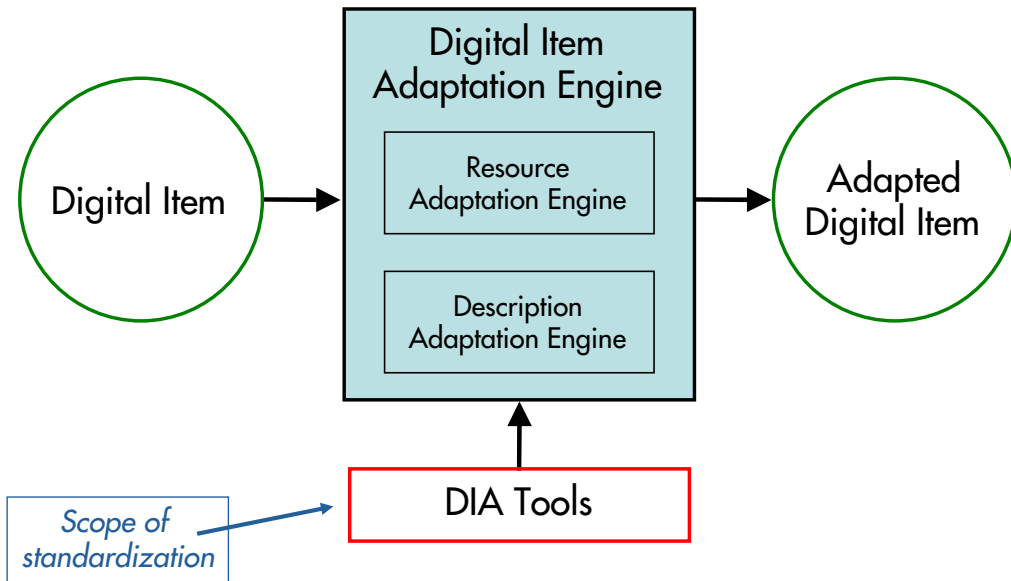

Relation between DIA and other MPEG-21 parts

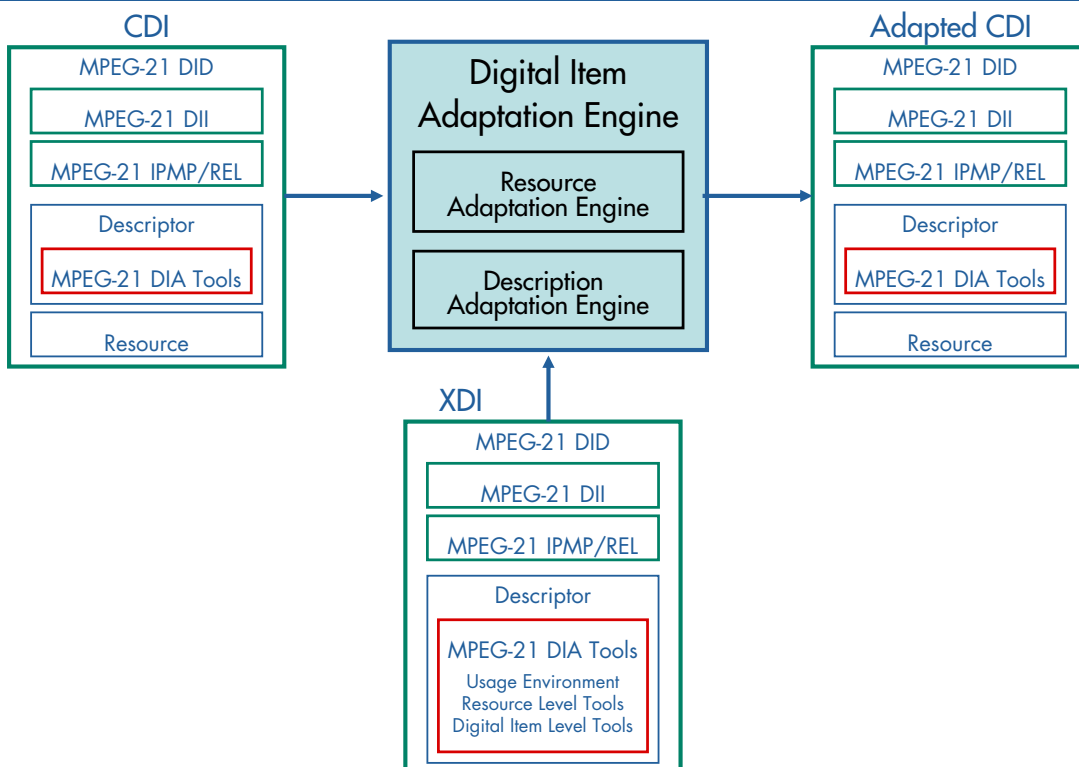

- User Characteristics
- Terminal Capabilities
- Network Characteristics
- Natural Environment Characteristics
- Resource Adaptability
- Session Mobility

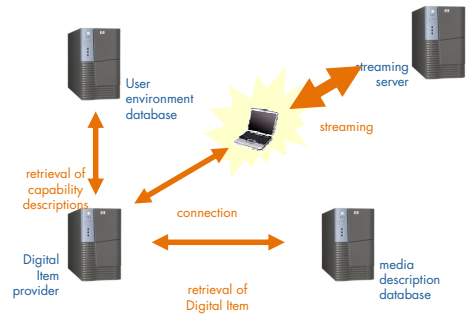

Overview of DIA Tools

Usage Environment Description Tools

- User Characteristics
- Terminal Capabilities
- Network Characteristics
- Natural Environment Characteristics

Digital Item Resource Adaptation Tools

- Bitstream Syntax Description
- Terminal and Network Quality of Service
- Metadata Adaptability

Digital Item Declaration Adaptation Tools

- Session Mobility
- DID Configuration Preferences
- DIA Description Messages

- BSDL (Bitstream Syntax Description Language)
- gBS Schema (generic Bitstream Syntax Schema)

• AdaptationQoS

• MetadataAdaptationHint

- A BSD describes the syntax (high level structure) of a binary media resource
- BSDL: XML schema based language to design specific bitstream syntax schemas for particular media formats
- gBS schema: generic schema enabling the construction of resource format independent bitstream syntax descriptions

Adaptation architecture

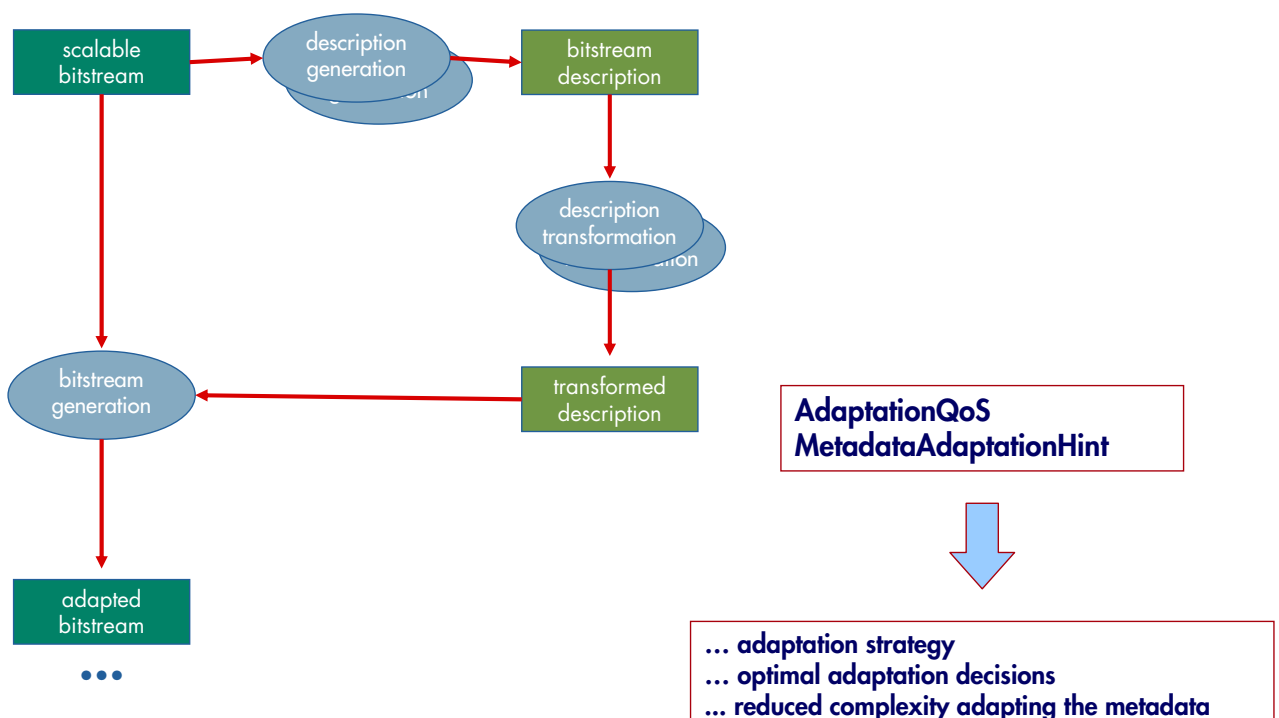

- *AdaptationQoS* specifies the relationship between constraints and feasible adaptation operations
- Constraints: BandwidthInKbps, ComputationTimeInMillisecs
- Utilities (qualities): PSNRIndB
- Adaptation Methods:
 - frameDroppingAndOrCoefficientDropping, requantization, fineGranularScalability, waveletReduction, spatialSizeReduction
- UtilityFunction:
 - describes possible adaptation operators and associated qualities using a set of constraint points as indexes
 - Linear interpolation is assumed between constraint points
- LookUpTable:
 - additional multi-dimensional sets of data to support more elaborate adaptation scenarios
- StackFunction
 - tool for describing the data in numerical function format

Metadata Adaptability

- *MetadataAdaptationHint* describes adaptation hint information pertaining to metadata within a digital item
- Hint: a set of syntactical elements with prior knowledge about the metadata that is useful for reducing the complexity of the metadata adaptation process

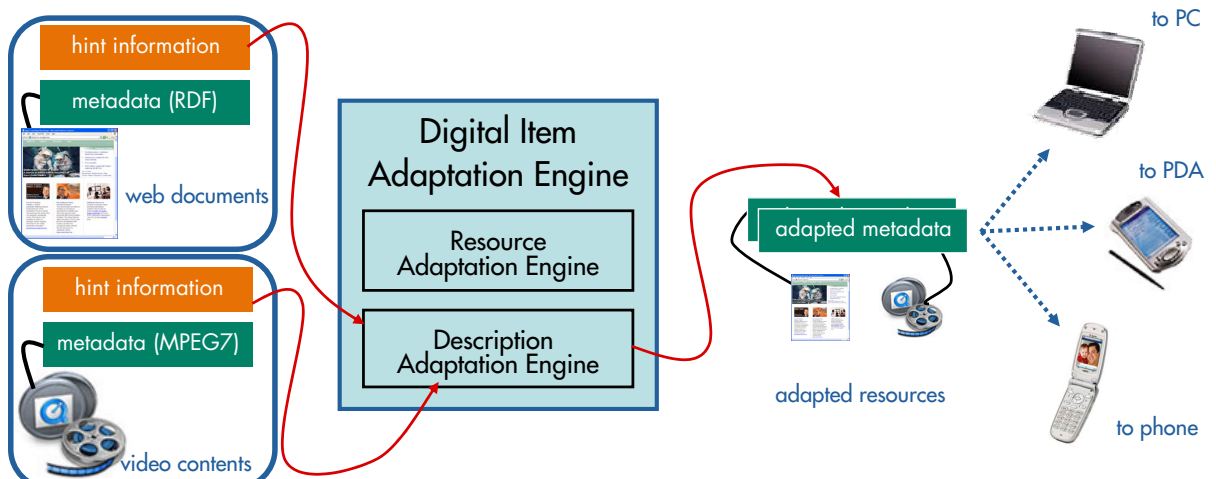

In some cases it is convenient to specify intrinsic operations based on a universal model for scalable bit-streams

A specified operation can be seen as a **link** that is composed of a mapping condition between identified parameters and an operation, which is conducted if this mapping is fulfilled

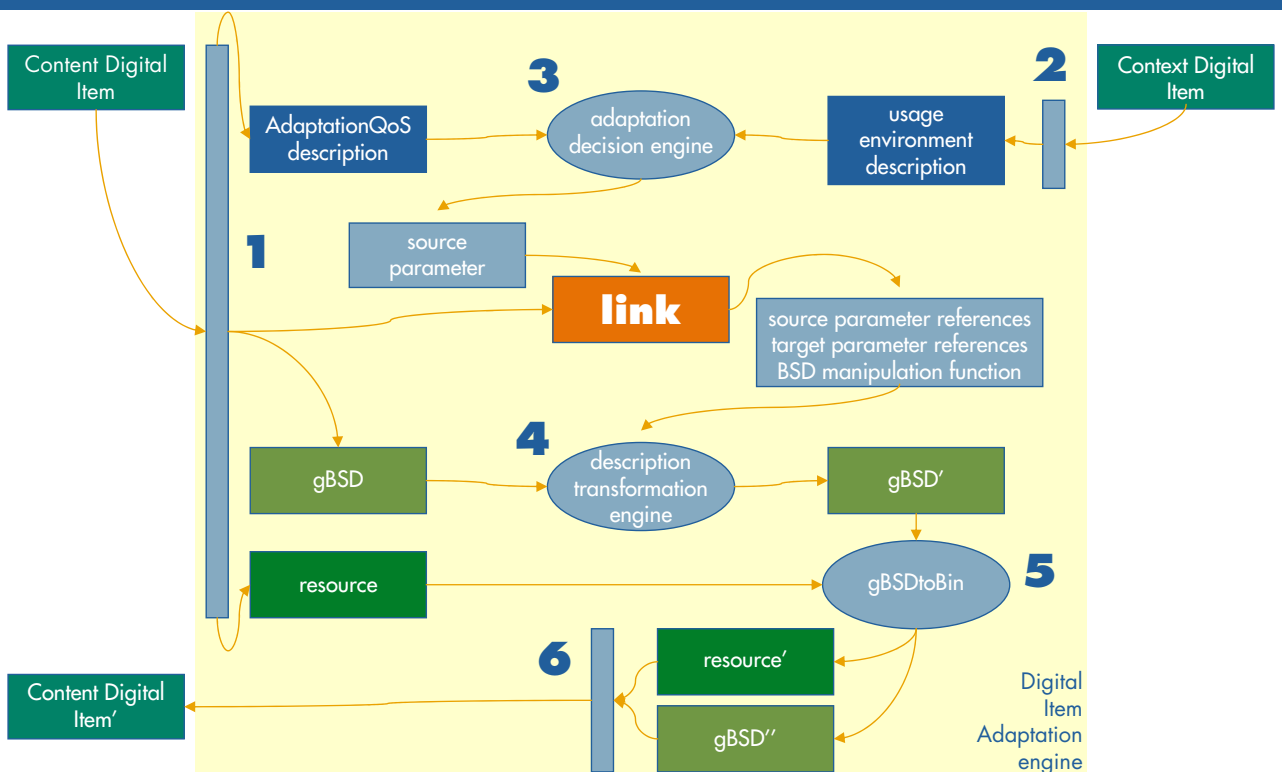
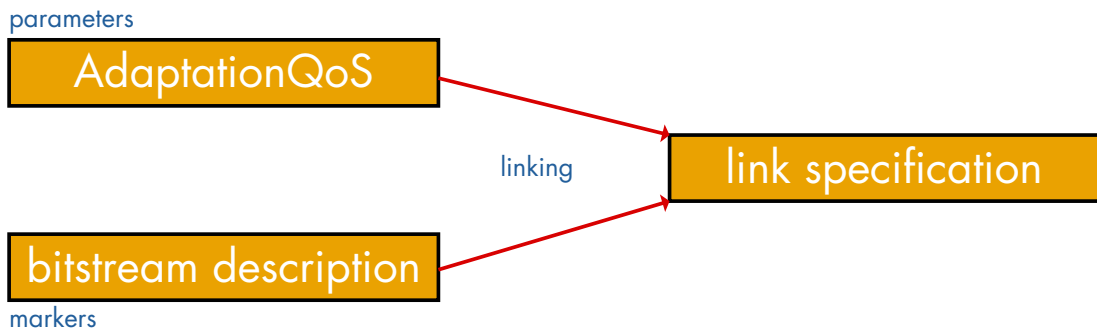

- Success of a standard depends on the availability of reference software
- Plan to use the software developed in Core Experiments (CE) as a basis
- Platform independence
- Future repository (requires membership)
 - <http://mpeg.nist.gov/cvswweb/MPEG-21/>
- Temporary repository
 - <http://www.titr.uow.edu.au/cgi-bin/mpeg-ref-sw.pl>
- Current main issue: parsing DID

Digital Item Processing

- Digital Items act as a structure for organizing resources and its descriptions
- Need a mechanism for defining a set of operations by which a terminal can process a DI or DID
- Currently considering to specify a set of operations that can be used to process DIs: Digital Item Method
- A DIM defines an intended method for configuring, manipulating and/or validating a DI

- Interoperability of Digital Items means that terminals must handle the DIs in a consistent manner
- Digital Item Methods provide a way to specify a selection of preferred procedures by which the DI should be handled at the DI level
 - a menu of user interaction possibilities
- Digital Item Processing encompasses all aspects of processing a DI from an application perspective
- Applications build DIP environments around a fundamental DIME

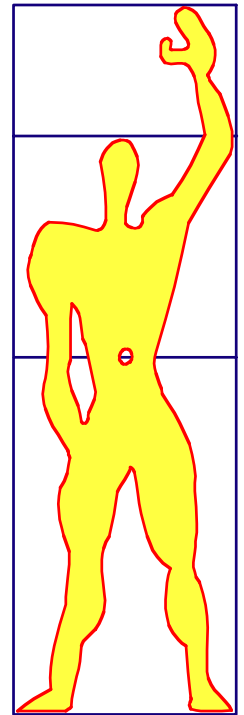

Digital Item processing terminology

- CDI — Content Digital Item
 - a DID containing the actual content
- DIBO — Digital Item Base Operation
- DIM — Digital Item Method
 - method that can be applied to a DID
 - DIME — DIM Engine
 - part of the terminal responsible for executing the DIM
 - DIML — DIM Language
- DIP — Digital Item Processing
- MI — Method Item
- PI — Processing Item
- XDI — Context Digital Item

Digital Item Processing

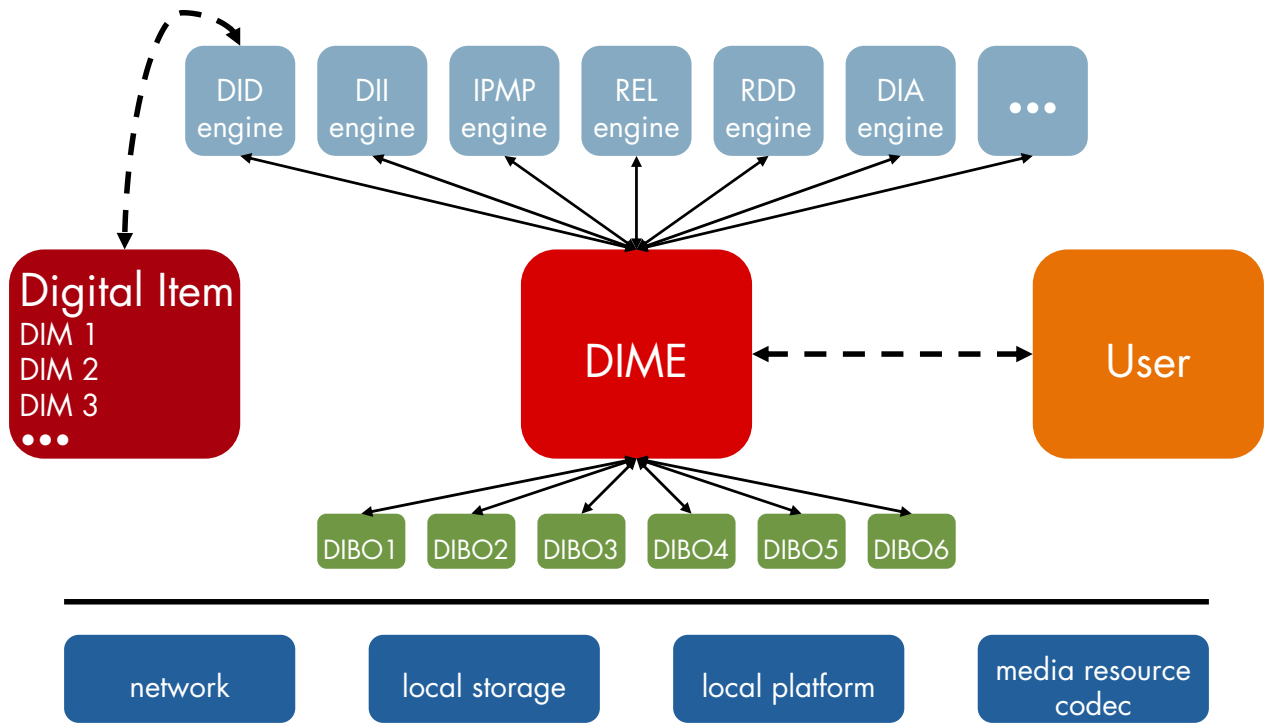

DIP flow control

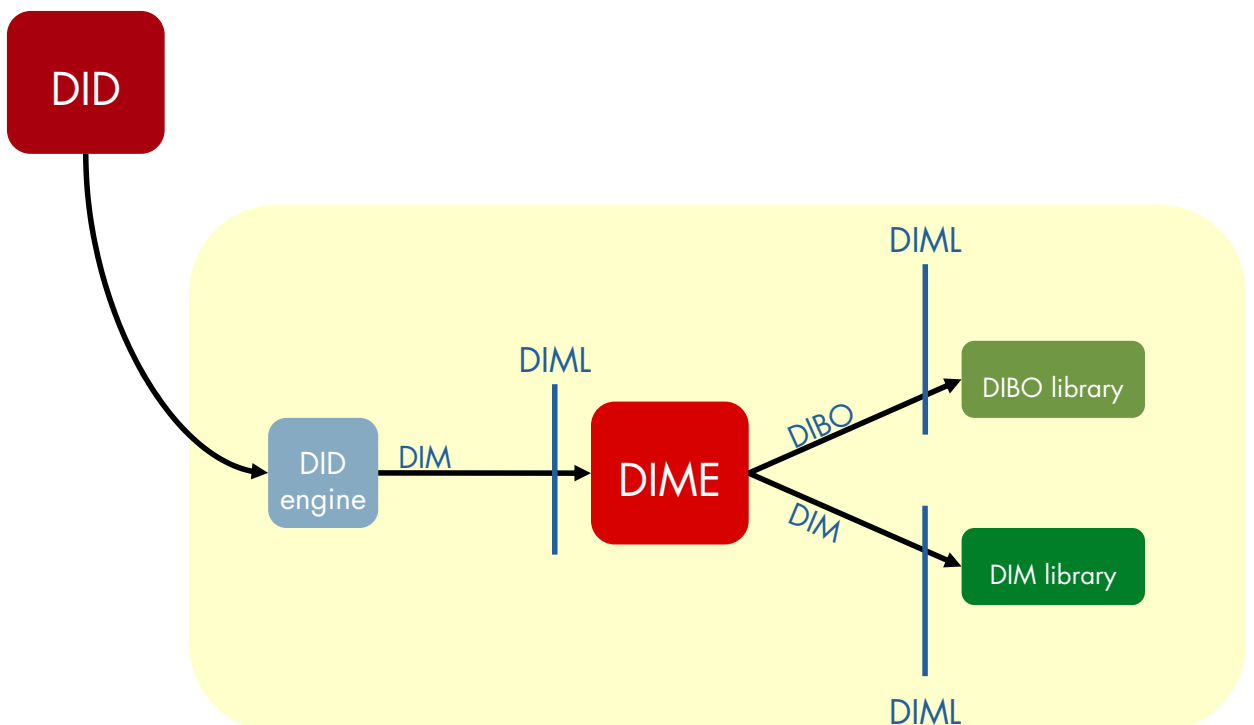

- An MPEG-21 file format shall be capable of storing MPEG-21 Digital Items
 - all components of the DI within a single file
- The MPEG-21 file format will inherit several concepts from MP4, in order to make 'multi-purpose' files possible

- Persistent association of information with DIs
- Accessibility
- Personal data
- Content representation
- Event reporting
- ...

Why is MPEG-21 relevant to you ?



- All rich media commerce on the Internet will be driven by MPEG-21
- Only companies that drive the standard will reap substantial profits
 - First to market
 - Licensing fees

The case against participation



- MPEG standards take 10 years to become profitable
- My competitor is not participating
- There are strong drivers in the standard and we can just leverage on them
 - Licensing fees are lower than the total cost of participating in the standardization effort
 - We do not have deep pockets
 - OS companies control the desktop anyway
- MPEG-21 is too complex for me

The case for participation



- Learn and work with the leading experts
- Understand standards from an evolutionary standpoint
- Work efficiently
- National Body protocol prevents power games
- Stay current on trends
- Be familiar with the competitive landscape
- Discover opportunities for your unique contributions



The case for participation (cont.)



- Score card: focus research on areas of competitive advantage, partner for the rest
- MPEG-21 is an extensive and complex standard
 - Only by participating you can maintain competitive advantages
 - Only by participating you learn with whom to partner

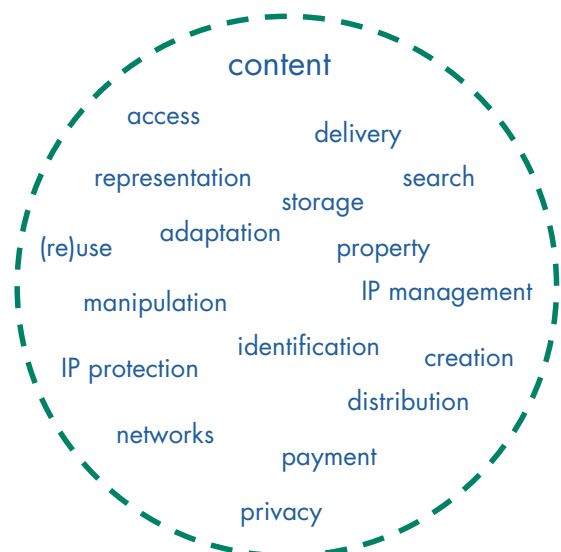

Work with the experts



- Under the MPEG ægis, the world's top experts collaborate to create the technology for rich media distribution frameworks
- Leverage on synergies, negotiate differences
- Co-invent new emergent properties
- Own intellectual properties instead of licensing them
- Develop technical partnerships that can evolve in fruitful business partnerships
- Learn what products are on the horizon
- Learn who your competitors will be before product development starts

How to make money



- Patent your unique contributions & submit patent statements to ISO
- Participate in the industrial forum to build markets
- Share in the licensing revenue stream
- Have products ready before the standard is published
- Build business alliances at an early stage
- Know the competition



What can scientists contribute to MPEG-21 ?



- Researchers perform long-term research and can pursue activities not yet on a product horizon
- Academia has vast pools of inexpensive brain power

Play to win



- MPEG groups the world's leaders in rich media
- Leaders win by competing with other leaders





What can you do for your founding agencies regarding MPEG-21?

Time horizon

- Development time horizon is based on product cycle and vintage chart size
 - Must be able to predict components available for purchase
 - Typically about 4 years
- Research time horizon is based on fundamental breakthroughs that allow paradigm shifts
 - Emergent properties mature over long periods
 - Typically about 10 years
- MPEG-21 is more than 4 years away from general adoption



- What is MPEG-21 ?
 - An open framework for multimedia delivery & consumption
- Why is MPEG-21 relevant to you ?
 - All rich media commerce will be driven by MPEG-21
- What can you contribute to MPEG-21 ?
 - Your unique expertise
- The bottom line
 - You have the expertise and credibility to successfully represent your employer's interests in MPEG-21

